

IV. EXERCISES & FLOW SCHEMATICS

Contents:	Page:
Single Syringe Mode	4.1
Plumbing	4.1
Exercise	4.5
Multiple Syringe Mode	4.12
Plumbing	4.12
Exercise	4.12
Reciprocating Mode	4.18
Plumbing	4.18
Exercise	4.22
Gradient Mode	4.26
Plumbing	4.26
Exercise	4.28
Continuous Flow Gradient Mode	4.35
Plumbing	4.35
Linking Files	4.37

Single Syringe Mode

Plumbing

A MicroPro pump for single syringe operation can be configured with a variety of options. The following figures illustrate the flow schematics for these various options.

Figure 4.1 shows a μ Pro fitted with low pressure valves for intake and output.

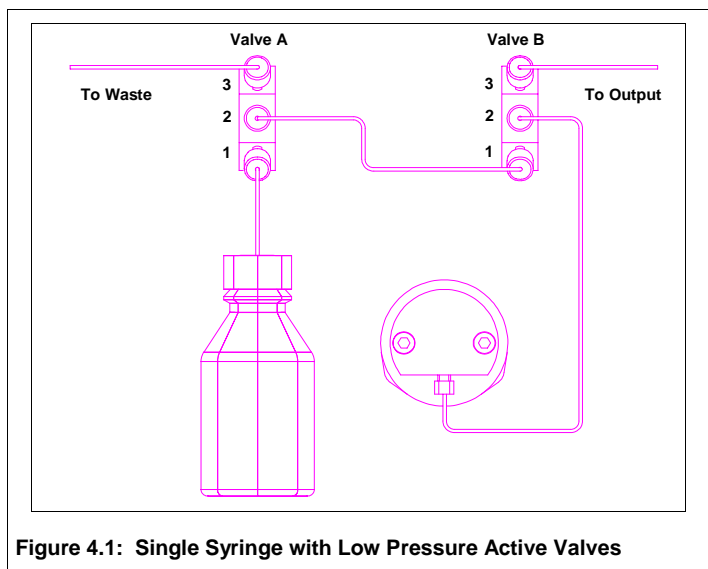

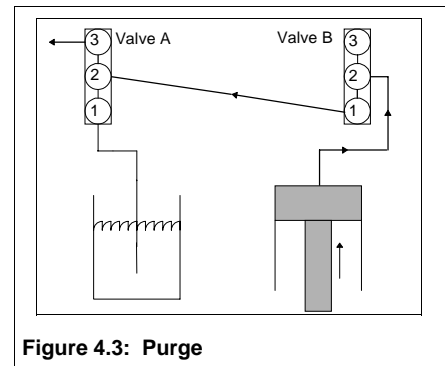
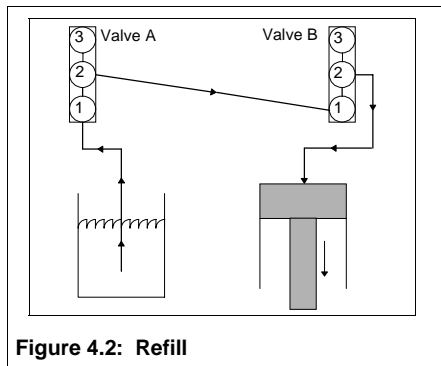

Figure 4.2 illustrates the flow schematic when the syringe refills. When the syringe piston retracts to refill, ports 1 and 2 are connected on valves A and B. The suction created by retracting the piston pulls fluid from the reservoir, through ports 1 and 2 of valve A. The fluid is pulled through the line connecting port 2 on valve A and port 1 on valve B, and consequently through the line connecting the syringe with port 2 on valve B.

Figure 4.3 illustrates the flow schematic when the syringe is being purged. When the syringe is being purged, ports 2 and 3 are connected on valve A, and ports 1 and 2 are connected on valve B. As the syringe piston moves forward, fluid is pushed through the line connecting the syringe to port 2 on valve B, out the line connecting port 1 on valve B and port 2 on valve A, and out the line connected to port 3 on valve A.

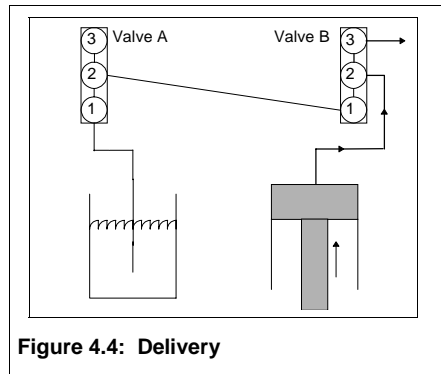

Figure 4.4 illustrates the flow schematic when the syringe is delivering to the output. When the syringe is delivering to the system output, ports 2 and 3 on valve B are connected. As the syringe piston moves forward, fluid is pushed through the line connecting the syringe to port 2 on valve B, and out the line connected to port 3 on valve B.

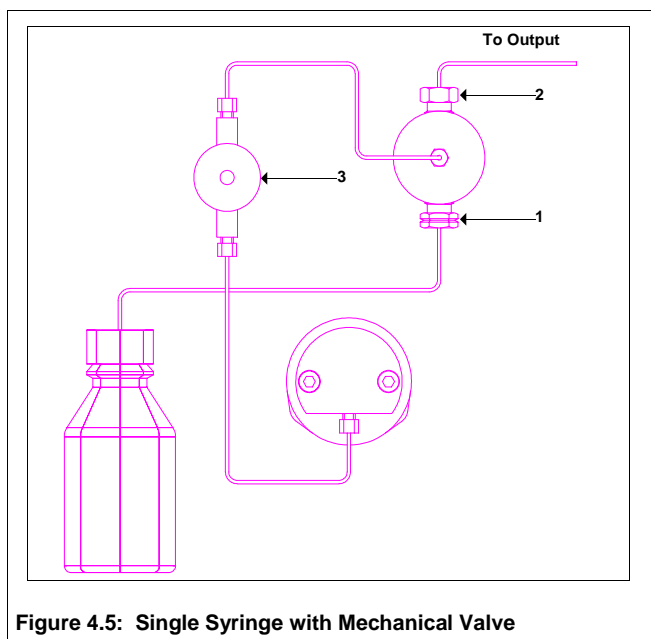

Figure 4.5 shows a μ Pro fitted with mechanical valves and a pressure transducer.

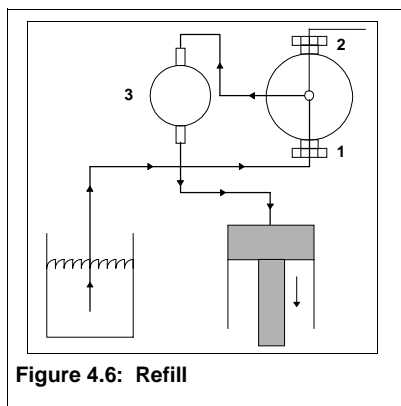

Figure 4.6 illustrates the flow schematic when the syringe is refills. When the syringe piston retracts to refill, fluid is pulled from the solvent reservoir to the syringe through the inlet valve (1) and transducer (3).

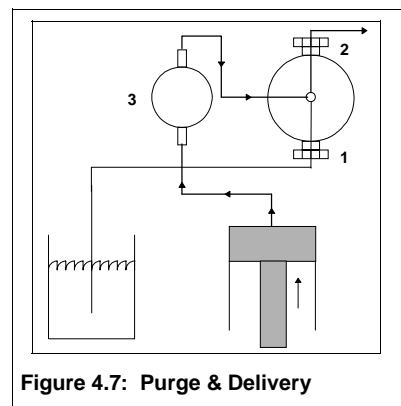

Figure 4.7 illustrates the flow schematic when the syringe is being purged and when the syringe is delivering to the system output. No automatic purge valve is installed on μ Pro pumps using mechanical valves. Consequently, flow delivery when the syringe is purging is the same as when the syringe is delivering to the pump output (depending on the nature of your setup, you may need to take additional precautions, such as installing an external valve, or disconnecting the outlet valve from any downstream devices, when purging μ Pro systems with mechanical valves, since the purge flow rate is typically higher than your normal operating flow rate).

When the syringe is delivering to the system output, fluid is pushed through the line connecting the syringe to the pressure transducer (3) and out the line connected to the outlet valve (2).

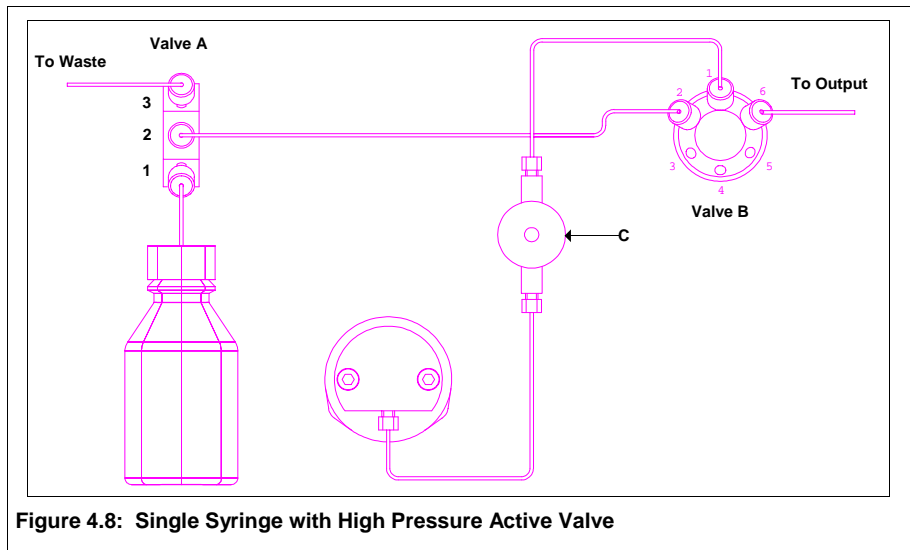

Figure 4.8 shows a μ Pro fitted with a low pressure valve, a high pressure valve, and a pressure transducer.

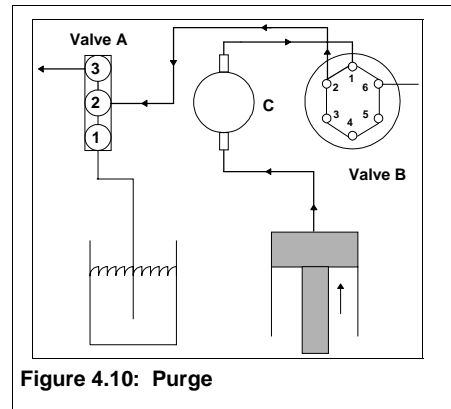
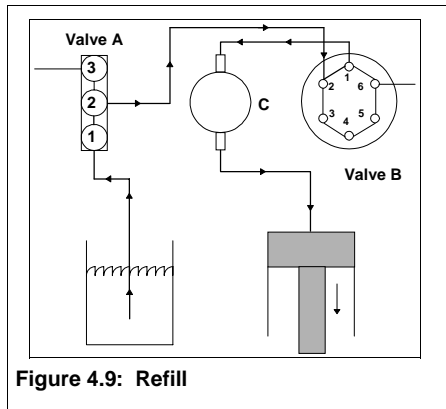

Figure 4.9 illustrates the flow schematic when the syringe refills. When the syringe piston retracts to refill, ports 1 and 2 are connected on valves A and B. The suction created by retracting the piston pulls fluid from the reservoir, through ports 1 and 2 of valve A and through the line connecting valves A and B. The fluid continues through the line connecting port 1 of valve B and the pressure transducer (C) and the line connecting the pressure transducer to the syringe.

Figure 4.10 illustrates the flow schematic when the syringe is being purged. Ports 2 and 3 are connected on Valve A and ports 1 and 2 are connected on valve B. As the syringe moves forward, fluid is pushed through the line connecting the syringe to the pressure transducer (C) and the line connecting the transducer to valve B. The fluid is transferred to the line connecting port 2 of valves A and B and out the line connected to port 3 of valve A.

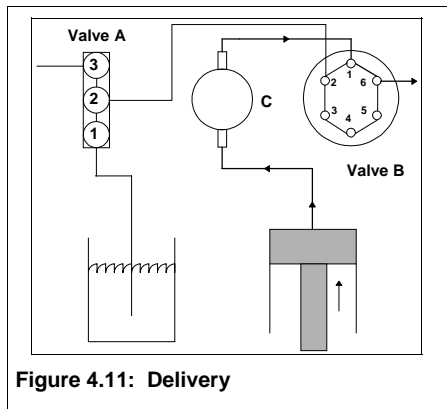

Figure 4.11 illustrates the flow schematic when the syringe is delivering to the output. When the syringe is delivering to the system output, ports 1 and 6 of valve B are connected. When the syringe moves forward, fluid is pushed through the line connecting the syringe to the pressure transducer (C) and the line connecting the transducer to valve B. The fluid is transferred to port 6 of valve B and out the line connected at that point.

Exercise

In the next several pages, we will go through, step-by-step, an exercise which will illustrate several programming features of the μ Pro. The exercise will show how to program a new file to run the pump at a constant flow rate, how to activate external events during a program, how to ramp the flow, how to step the flow, and how to run a negative flow rate.

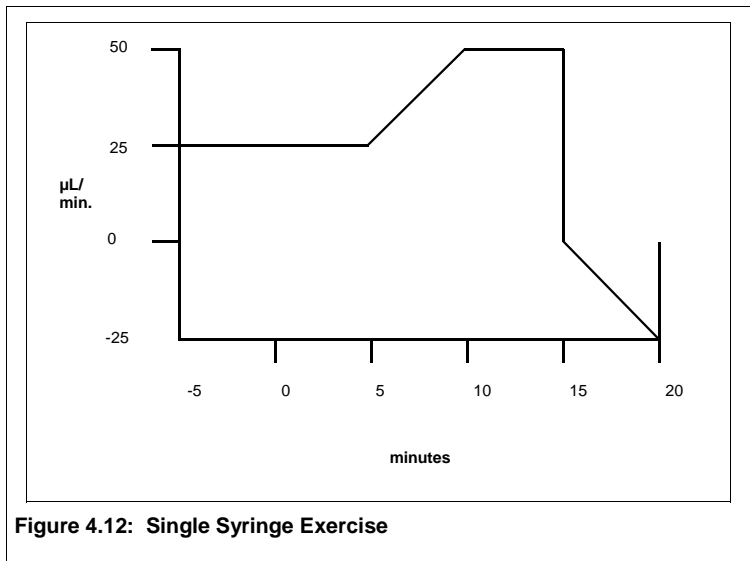

Table 4.1: Single Syringe Exercise

Program Step	Time	Flow	Events
Equilibration	5.00	25 μ L	1 ON
Step 1	0.00	25 μ L	1 OFF
Step 2	5.00	25 μ L	2 ON
Step 3	5.05	CLEAR	2 OFF
Step 4	10.00	50 μ L	
Step 5	15.00	50 μ L	
Step 6	15.01	0 μ L	
Step 7	20.00	-25 μ L	
Step 8	20.01	0 μ L	

Figure 4.12 graphically represents the file we will create. Table 4.1 represents a listing of the file steps. The file we will program does not represent any particular application; but, is intended to convey an understanding of the different kinds of programming features available.

First, the exercise will illustrate how to create a new file and enter a high pressure limit of 1000 psi and a low pressure limit of 50 psi. You will also verify that the control mode of operation is flow.

Next, you will program your equilibration parameters. In this exercise those parameters are a five minute equilibration period at a flow rate of 25 μ L/min. You will also activate event 1 at the beginning of equilibration.

At the end of equilibration, we will run the syringe at a flow rate of 20 $\mu\text{L}/\text{min}$. for five minutes and turn off event 1.

The second program step will turn on event 2.

Step three of the program will define the beginning point of a ramp of the flow to 50 $\mu\text{L}/\text{min}$ during the next five minutes, and we will use step four to define the end point of the flow ramp.

The next step will hold at 50 $\mu\text{L}/\text{min}$ for another five minutes.

The next few steps will set the flow to zero and program a negative ramp in flow from 0 to -25 $\mu\text{L}/\text{min}$ for 5 minutes and then set the flow to zero again.

First: Create a New File

To create a new file, select softkey B (EDIT) from the Main Menu. The display will change to screen B. Select softkey B (NEW FILE) from screen B. The display will change to screen B1 and the cursor will blink on the FILE # field. Enter a valid file number and press ENTER.

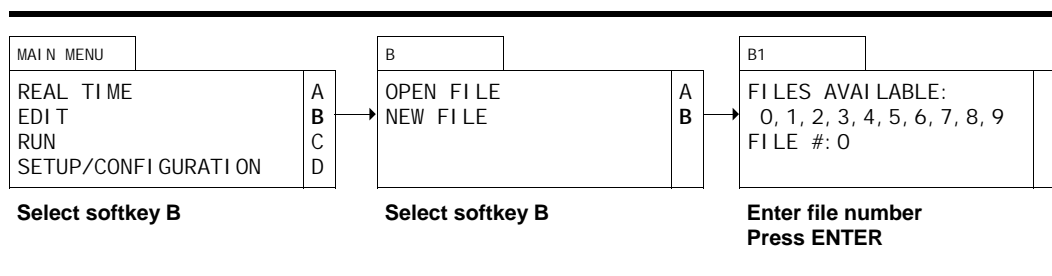

Second: Enter General File Parameters

Once a valid file number has been entered, the display will change to display screen B2.1 and the cursor will blink on the HI LIMIT field. Enter **1000** and press ENTER. The cursor will move to the LO LIMIT field. Enter **50** and press ENTER. The cursor will move to the CONTROL field. Press softkey D to toggle to constant flow mode and press ENTER.

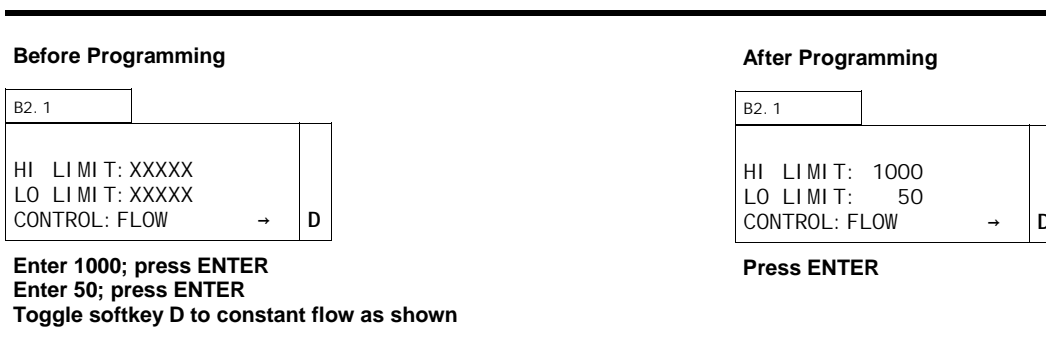

Third: Program Equilibration

Once the general file parameters have been entered, the display will change to display screen B2.2 and the cursor will blink on the EQUIL TIME field. Enter **5** and press ENTER since our exercise calls for a 5 minute equilibration.

The cursor will move to the FLOW field and blink. Enter **25** and press ENTER since our exercise calls for a flow rate of 25 μ L/min.

The cursor will move to the ON field and blink to the right of the first 0. The first 0 corresponds to the contact closure labeled 1 and 2 on the I/O board. Since we want to turn this contact on at the beginning of equilibration, press **1** and ENTER.

The cursor will move to the second ON field; however, since we only need to activate the first contact, press softkey D to scroll to the program screens.

Before Programming

B2.2			
EQUIL TIME:	0.00		
FLOW:	0.00		
ON:	0 0 0 0 0 0	↑	C
		↓	D

Enter **5** for Equil Time; press ENTER
 Enter **25**; for Flow; press ENTER
 Enter **"1"** in first ON field; press ENTER

After Programming

B2.2			
EQUIL TIME:	5.00		
FLOW:	25.00		
ON:	1 0 0 0 0 0	↑	C
		↓	D

Press softkey **D**

Fourth: Step One

Once softkey D has been pressed in screen B2.2, the display will change to display screen B2.3 and the cursor will blink on the TIME field. Press ENTER to accept the default value of 0.00 (all files need a zero start time).

The cursor will move to the FLOW field. Press ENTER to accept the value carried forward from the Equilibration screen.

The cursor will move to the first ON field. Press **0** to turn off the first event. Press ENTER. The cursor will move to the second ON field. Since we only need to turn off the first contact, press softkey A to INSERT another program screen.

Before Programming

B2.3			
TIME:	0.00	INS	A
FLOW:	25.00	DEL	B
		↑	C
ON:	1 0 0 0 0 0		

Press ENTER to accept Time **0**
 Press ENTER to accept Flow
 Enter **"0"** in first ON field; press ENTER

After Programming

B2.3			
TIME:	0.00	INS	A
FLOW:	25.00	DEL	B
		↑	C
ON:	0 0 0 0 0 0		

Press softkey **A** to INSERT a new screen

Fifth: Step Two

Since the μ Pro generates a linear change between any two end points, we need to establish the first end point at five minutes to start the ramp from 25 μ L/min to 50 μ L/min. This program screen will establish that starting point.

Once softkey A has been pressed, the display will call up a new screen B2.3. The cursor will blink in the TIME field. Enter 5 and press ENTER.

The cursor will move to the FLOW field. Press ENTER to accept the displayed value.

The cursor will move to the first ON field. Press ENTER to move to the second event and press 1 to turn on the second event. Press ENTER. The cursor will move to the third ON field; however, since we only need to activate the second contact, press softkey A to INSert another program screen.

Before Programming

B2.3			
TIME:	-1.00	INS	A
FLOW:	25	DEL	B
		↑	C
ON:	0 0 0 0 0 0		

Enter 5 for Time; press ENTER
Press ENTER to accept Flow
Press ENTER; enter "1" in second ON field;
press ENTER

After Programming

B2.3			
TIME:	5.00	INS	A
FLOW:	25	DEL	B
		↑	C
ON:	0 1 0 0 0 0		

Press softkey A to INSert a
new screen

Sixth: Step Three

Once softkey A has been pressed, the display will call up a new screen B2.3.

The only function we need to execute is to turn off the second contact closure event. To do this, enter 5.05 in the TIME field (to turn off the second event .05 minutes after the start of the program). Press ENTER.

The cursor will move to the FLOW field. Press CLEAR to enter an event activity without affecting flow (NA will now be displayed in the FLOW field).

The cursor will move to the first ON field. Press ENTER to accept the off (0) value. The cursor will move to the second ON field. Press 0 to turn off the second event. Press ENTER. The cursor will move to the third ON field; however, since we only need to deactivate the second contact, press softkey A to INSert another program screen.

Before Programming

B2.3			
TIME:	-1.00	INS	A
FLOW:	25.00	DEL	B
		↑	C
ON:	0 1 0 0 0 0		

Press 5.05 for Time; press ENTER
Press CLEAR to accept not affect FLOW; press ENTER
Press ENTER to move to second ON field; press "0" in
second ON field; press ENTER

After Programming

B2.3			
TIME:	5.05	INS	A
FLOW:	NA	DEL	B
		↑	C
ON:	0 0 0 0 0 0		

Press softkey A to INSert a
new screen

Seventh: Step Four

Once softkey A has been pressed, the display will call up a new screen B2.3. The cursor will blink in the TIME field. Enter **10** and press ENTER.

The cursor will move to the FLOW field. Enter **50** and press ENTER.

The cursor will move to the first event field. Since we do not need to activate any events, press softkey A to INSERT a new screen.

Before Programming

B2.3				
TIME:	-1.00	INS	A	
FLOW:	25	DEL	B	
		↑	C	
ON:	0 0 0 0 0 0			

Enter **10** for Time; press ENTER
Enter **50** µL/min. for Flow; press ENTER

After Programming

B2.3				
TIME:	10.00	INS	A	
FLOW:	50	DEL	B	
		↑	C	
ON:	0 0 0 0 0 0			

Press softkey A to INSERT a new screen

Eighth: Step Five

Once softkey A has been pressed, the display will call up a new screen B2.3. The cursor will blink in the TIME field. Enter **15** and press ENTER.

The cursor will move to the FLOW field. Press ENTER to accept displayed value.

The cursor will move to the first event field. Since we do not need to activate any events, press softkey A to INSERT a new screen.

Before Programming

B2.3				
TIME:	-1.00	INS	A	
FLOW:	50	DEL	B	
		↑	C	
ON:	0 0 0 0 0 0			

Enter **15** for Time; press ENTER
Enter **50** µL/min. for Flow; press ENTER

After Programming

B2.3				
TIME:	15.00	INS	A	
FLOW:	50	DEL	B	
		↑	C	
ON:	0 0 0 0 0 0			

Press softkey A to INSERT a new screen

Ninth: Step Six

Once softkey A has been pressed, the display will call up a new screen B2.3. the cursor will blink in the TIME field. Enter **15.01** and press ENTER.

The cursor will move to the FLOW field. Enter **0** and press ENTER.

The cursor will move to the first event field. Since we do not need to activate any events, press softkey A to INSert a new screen.

Before Programming

B2.3				
TIME:	-1.00	INS	A	
FLOW:	50	DEL	B	
		↑	C	
ON:	0 0 0 0 0 0			

Enter **15.01** for Time; press ENTER
Enter **0** $\mu\text{L}/\text{min.}$ for Flow; press ENTER

After Programming

B2.3				
TIME:	15.01	INS	A	
FLOW:	0	DEL	B	
		↑	C	
ON:	0 0 0 0 0 0			

Press softkey A to INSert a new screen

Tenth: Step Seven

Once softkey A has been pressed, the display will call up a new screen B2.3. the cursor will blink in the TIME field. Enter **20** and press ENTER.

The cursor will move to the FLOW field. Press CLEAR, enter **-25** and press ENTER.

The cursor will move to the first event field. Since we do not need to activate any events, press softkey A to INSert a new screen.

Before Programming

B2.3				
TIME:	-1.00	INS	A	
FLOW:	0	DEL	B	
		↑	C	
ON:	0 0 0 0 0 0			

Enter **20** for Time; press ENTER
Press CLEAR; enter **-25** $\mu\text{L}/\text{min.}$ for Flow;
press ENTER

After Programming

B2.3				
TIME:	20.00	INS	A	
FLOW:	-25	DEL	B	
		↑	C	
ON:	0 0 0 0 0 0			

Press softkey A to INSert a new screen

Eleventh: Step Eight

Once softkey A has been pressed, the display will call up a new screen B2.3. the cursor will blink in the TIME field. Enter **20.01** and press ENTER.

The cursor will move to the FLOW field. Enter **0** and press ENTER.

The cursor will move to the first event field. Since we are done programming, you may press softkey C to scroll up through the individual program screens.

Before Programming

B2.3				
TIME:	-1.00	INS	A	
FLOW:	50	DEL	B	
		↑	C	
ON:	0 0 0 0 0 0			

Enter **20.01** for Time; press ENTER
Enter **0** µL/min. for Flow; press ENTER

After Programming

B2.3				
TIME:	20.01	INS	A	
FLOW:	0	DEL	B	
		↑	C	
ON:	0 0 0 0 0 0			

Press softkey C to scroll up

Summary

You can press softkeys C and D to scroll through the program steps to review them and verify that they have been entered correctly. You may find it useful to make a table similar to that shown on Table 4.1 before programming.

Press DISPLAY and ΔMENU to return to the Main Menu.

Multiple Syringe Mode

Plumbing

The flow schematics for multiple syringe operation are the same as for single syringe operation (you may wish to consult the flow schematics and descriptions for single syringes starting on page 4.1), except there are more syringes.

Multiple syringe operation allows you to use a single “master” syringe to control up to three other syringe pumps. Files run in multiple syringe mode start at the same time (although, obviously, you can program zero flow for one or more of the syringes at time 000.00 and start them up later in the program). You can manifold the output of the syringes if you wish to combine their output to a single stream (though if you do this, you will need to account for the possibility of backflow), or run them completely independently to separate downstream systems.

Exercise

In the next several pages, we will go through, step-by-step, an exercise which will illustrate several programming features of the μ Pro. The exercise will show how to program a new file to run two syringes at different flow rates, how to run the pump at a constant flow rate and how to ramp the flow of a syringe.

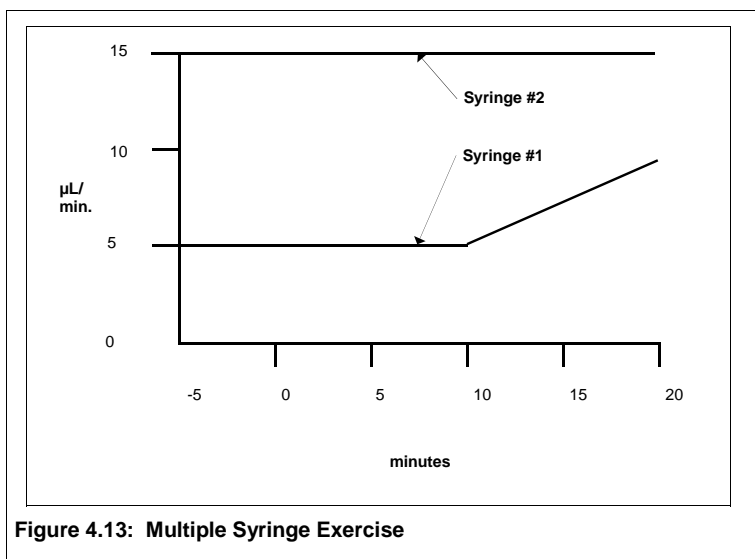

Figure 4.13: Multiple Syringe Exercise

Table 4.2: Multiple Syringe Exercise

Syringe #1

Program Step	Time	Flow
Equilibration	5.00	5µL
Step 1	0.00	5µL
Step 2	10.00	5µL
Step 3	20.00	10µL

Syringe #2

Program Step	Time	Flow
Equilibration	5.00	15µL
Step 1	0.00	15µL
Step 2	20.00	15µL

Figure 4.13 represents the file we will create. Table 4.2 represents a listing of the file steps. The file we will program does not represent any particular application; but, is intended to convey an understanding of the different kinds of programming features available. You may wish to consult the exercise for single syringe operation to see some of the other programming features.

First, the exercise will illustrate how to create a new file and enter a high pressure limit of 1000 psi and a low pressure limit of 50 psi. You will also verify that the control mode of operation is flow.

Next, you will program your equilibration parameters. In this exercise those parameters are a five minute equilibration period at a flow rate of 5 μ L/min for Syringe 1 and 15 μ L/min for Syringe 2.

The first program step of our exercise will continue under the conditions during equilibration.

After ten minutes, we will program Syringe 1 to ramp its flow to 10 μ L/min. over a ten minute period.

First: Create a New File

To create a new file, select softkey B (EDIT) from the Main Menu. The display will change to screen B. Select softkey B (NEW FILE) from screen B. The display will change to screen B1 and the cursor will blink on the FILE # field. Enter a valid file number and press ENTER.

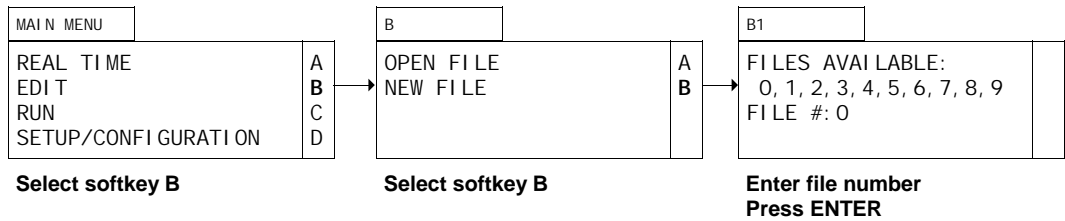

Second: Enter General File Parameters/Syringe #1

Once a valid file number has been entered, the display will change to display screen B2.1 and the cursor will blink on the HI LIMIT field. Enter **1000** and press ENTER. The cursor will move to the LO LIMIT field. Enter **50** and press ENTER. The cursor will move to the CONTROL field. Press softkey D to toggle to constant flow mode and press ENTER.

Before Programming

B2.1		
	S#1→	A
HI LIMIT: XXXXX		
LO LIMIT: XXXXX		
CONTROL: FLOW	→	D

Enter 1000; press ENTER
Enter 50; press ENTER
Toggle softkey D to constant flow as shown

After Programming

B2.1		
	S#1→	A
HI LIMIT: 1000		
LO LIMIT: 50		
CONTROL: FLOW	→	D

Press ENTER

Third: Program Equilibration/Syringe #1

Once the general file parameters have been entered, the display will change to display screen B2.2 and the cursor will blink on the EQUIL TIME field. Enter **5** and press ENTER since our exercise calls for a 5 minute equilibration.

The cursor will move to the FLOW field and blink. Enter **5** and press ENTER since our exercise

Before Programming

B2.2		
EQUIL TIME: 0.00		
FLOW: 0.00		
ON: 0 0 0 0 0 0	↑	C
	↓	D

Enter 5 for Equil Time; press ENTER
Enter 5 for Flow; press ENTER

After Programming

B2.2		
EQUIL TIME: 5.00		
FLOW: 5.00		
ON: 0 0 0 0 0 0	↑	C
	↓	D

Press softkey D

calls for a flow rate of 5 $\mu\text{L}/\text{min}$.

The cursor will move to the ON field and blink to the right of the first 0. Since we do not need to activate any events, press softkey D to scroll to the program screens.

Fourth: Syringe #1 - Step One

Once softkey D has been pressed in screen B2.2, the display will change to display screen B2.3 and the cursor will blink on the TIME field. Press ENTER to accept the default value of 0.00 (all files need a zero start time).

The cursor will move to the FLOW field. Press ENTER to accept the value carried forward from the Equilibration screen.

The cursor will move to the first ON field and blink to the right of the first 0. Since we do not need to activate any events, press softkey A to INSERT another program screen.

Before Programming

B2.3			
TIME:	0.00	INS	A
FLOW:	5	DEL	B
		↑	C
ON:	0 0 0 0 0 0		

Press ENTER to accept Time 0
Press ENTER to accept 5 $\mu\text{L}/\text{min}$.

After Programming

B2.3			
TIME:	0.00	INS	A
FLOW:	5	DEL	B
		↑	C
ON:	0 0 0 0 0 0		

Press softkey A to INSERT a new screen

Fifth: Syringe #1 - Step Two

Since the μPro generates a linear change between any two end points, we need to establish the first end point at ten minutes to start the ramp from 5 $\mu\text{L}/\text{min}$. to 10 $\mu\text{L}/\text{min}$. This program screen will establish that starting point.

Once softkey A has been pressed, the display will call up a new screen B2.3. It will appear identical to the screen just programmed and the cursor will blink in the TIME field. Enter 10 and press ENTER.

The cursor will move to the FLOW field. Press ENTER to accept the displayed value.

The cursor will move to the first event field. Since we do not need to activate any events, press softkey A to INSERT a new screen.

Before Programming

B2.3			
TIME:	-1.00	INS	A
FLOW:	5	DEL	B
		↑	C
ON:	0 0 0 0 0 0		

Enter 10 for Time; press ENTER
Press ENTER to accept Flow

After Programming

B2.3			
TIME:	10.00	INS	A
FLOW:	5	DEL	B
		↑	C
ON:	0 0 0 0 0 0		

Press softkey A to INSERT a new screen

Sixth: Syringe #1 - Step Three

Once softkey A has been pressed, the display will call up a new screen B2.3. It will appear identical to the screen just programmed and the cursor will blink in the TIME field. Enter **20** and press ENTER.

The cursor will move to the FLOW field. Enter **10** and press ENTER.

The cursor will move to the first event field. Since we do not need to activate any events and are done with programming Syringe #1, ΔMENU twice to return to screen B2.1.

Before Programming

B2.3				
TIME:	-1.00	INS	A	
FLOW:	5	DEL	B	
		↑	C	
ON:	0 0 0 0 0 0			

Enter **20** for Time; press ENTER
Enter **10** μL/min. for Flow; press ENTER

After Programming

B2.3				
TIME:	20.00	INS	A	
FLOW:	10	DEL	B	
		↑	C	
ON:	0 0 0 0 0 0			

Press ΔMENU twice to return to screen B2.1

Seventh: Enter General File Parameters/Syringe #2

Once you have pressed ΔMENU twice, the display will change to display screen B2.1 and the cursor will blink on the HI LIMIT field. Press softkey A to toggle to S#2. Enter **1000** and press ENTER. The cursor will move to the LO LIMIT field. Enter **50** and press ENTER. The cursor will move to the CONTROL field. Press softkey D to toggle to constant flow mode and press ENTER.

Before Programming

B2.1				
		S#1→	A	
HI LIMIT:	XXXXX			
LO LIMIT:	XXXXX			
CONTROL:	FLOW	→	D	

Toggle softkey A
Enter **1000**; press ENTER
Enter **50**; press ENTER
Toggle softkey D to constant flow as shown

After Programming

B2.1				
		S#2→	A	
HI LIMIT:	1000			
LO LIMIT:	50			
CONTROL:	FLOW	→	D	

Press ENTER

Eighth: Program Equilibration/Syringe #2

Once the general file parameters have been entered, the display will change to display screen B2.2 and the cursor will blink on the EQUIL TIME field. Enter **5** and press ENTER since our exercise calls for a 5 minute equilibration.

The cursor will move to the FLOW field and blink. Enter **15** since our exercise calls for a flow rate of 15 $\mu\text{L}/\text{min}$. and press ENTER.

Before Programming

B2.2			
EQUIL TIME:	0.00		
FLOW:	0.00		
ON: 0 0 0 0 0 0		↑	C
		↓	D

Enter **5** for Equil Time; press ENTER
Enter **15** for Flow; press ENTER

After Programming

B2.2			
EQUIL TIME:	5.00		
FLOW:	15.00		
ON: 0 0 0 0 0 0		↑	C
		↓	D

Press softkey **D**

Ninth: Syringe #2 - Step One

Once softkey D has been pressed in screen B2.2, the display will change to display screen B2.3 and the cursor will blink on the TIME field. Press ENTER to accept the default value of 0.00 (all files need a zero start time).

The cursor will move to the FLOW field. Press ENTER to accept the value carried forward from the Equilibration screen.

The cursor will move to the first ON field and blink to the right of the first 0. Since we do not need to activate any events, press softkey A to INSERT another program screen.

Before Programming

B2.3			
TIME:	0.00	INS	A
FLOW:	15	DEL	B
		↑	C
ON: 0 0 0 0 0 0			

Press ENTER to accept Time 0
Press ENTER to accept Flow

After Programming

B2.3			
TIME:	0.00	INS	A
FLOW:	15	DEL	B
		↑	C
ON: 0 0 0 0 0 0			

Press softkey **A** to INSERT a new screen

Step Ten: Second Program Screen/Syringe #2

Once softkey A has been pressed, the display will call up a new screen B2.3. It will appear identical to the screen just programmed and the cursor will blink in the TIME field. Enter **20** and press ENTER.

The cursor will move to the FLOW field. Press ENTER to accept displayed value.

The cursor will move to the first event field. Since we are done programming, you may press softkey C to scroll up through the individual program screens.

Before Programming

B2.3				
TIME:	-1.00	INS	A	
FLOW:	5	DEL	B	
		↑	C	
ON:	0 0 0 0 0 0			

Enter 10 for Time; press ENTER
Press ENTER to accept Flow

After Programming

B2.3				
TIME:	10.00	INS	A	
FLOW:	5	DEL	B	
		↑	C	
ON:	0 0 0 0 0 0			

Press softkey C to scroll up

Summary

You can press softkeys C and D to scroll through the program steps to review them and verify that they have been entered correctly. You may find it useful to make a table similar to that shown on Table 4.2 before programming.

Press DISPLAY and ΔMENU to return to the Main Menu.

Reciprocating Mode

Plumbing

A μ Pro pump for reciprocating operation can be configured with a variety of options. The following figures illustrate the flow schematics for these various options.

Figure 4.14 shows a μ Pro fitted with mechanical valves for intake and output.

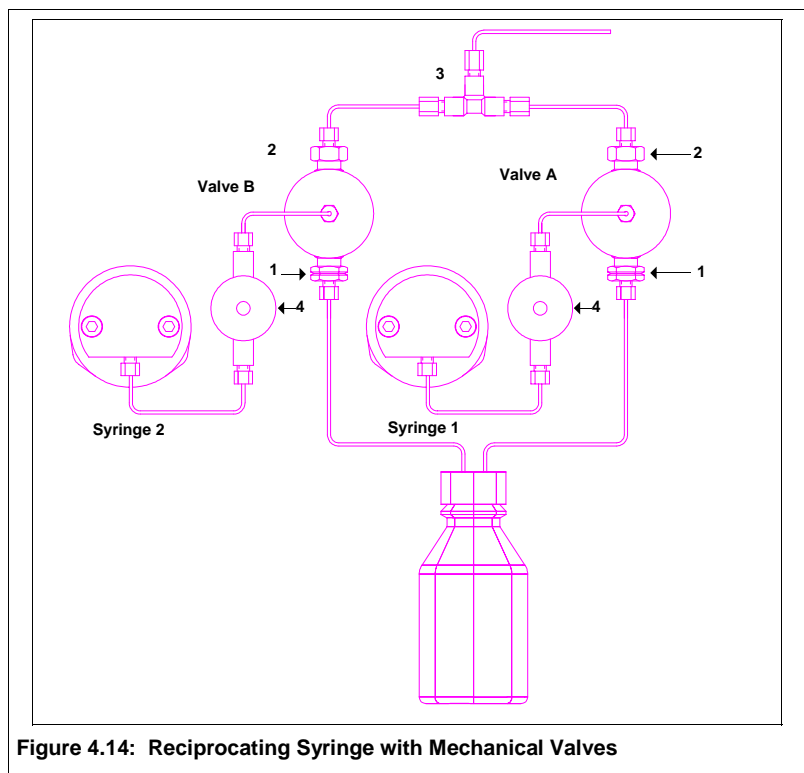

Figure 4.14: Reciprocating Syringe with Mechanical Valves

Figure 4.15 illustrates the flow schematic when the syringe refills. When the syringe piston retracts to refill, fluid is pulled from the solvent reservoir to the syringe through the inlet valve (1).

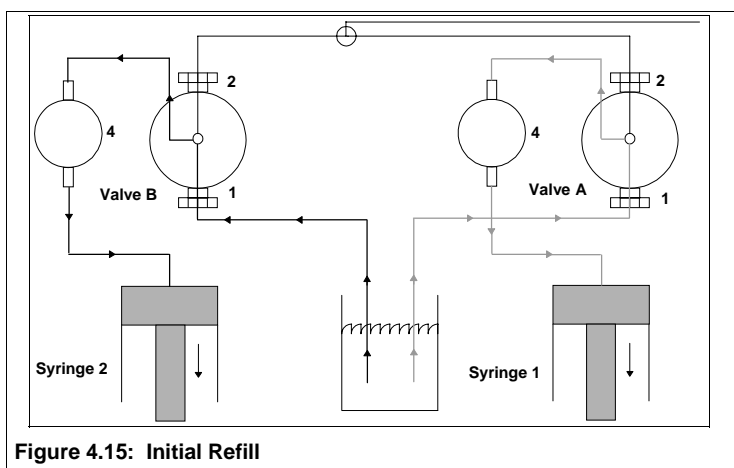

Figure 4.15: Initial Refill

Figure 4.16 illustrates the flow schematic when the syringe is being purged. No automatic purge valve is installed on Pro pumps using mechanical valves. Consequently, flow delivery when the syringe is purging is the same as when the syringe is delivering to the pump output (depending on the nature of your setup, you may need to take additional precautions, such as installing an

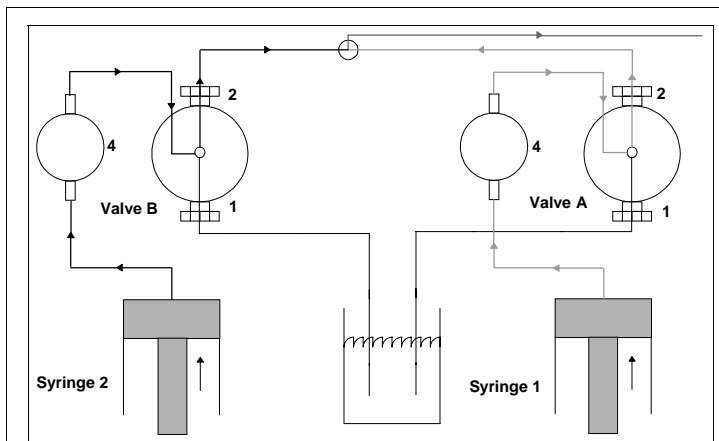

Figure 4.16: Purge

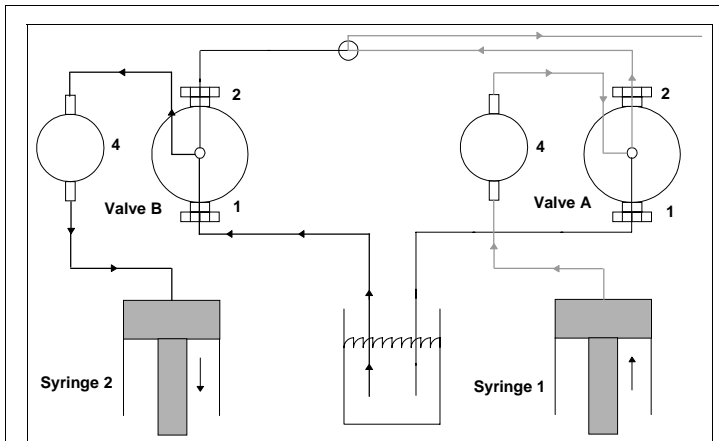

Figure 4.17: Syringe 1 Delivery; Syringe 2 Refill

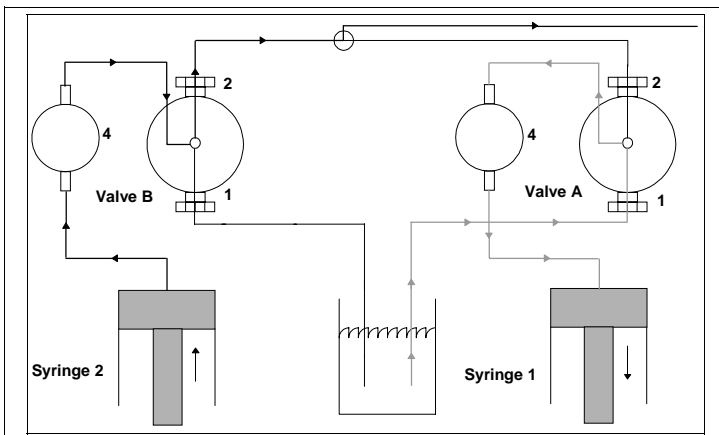

Figure 4.18: Syringe 1 Refill; Syringe 2 Delivery

external valve, or disconnecting the outlet from any downstream devices, when purging Pro systems with mechanical valves, since the purge flow rate is typically higher than your normal operating flow rate).

When the syringe is delivering to the system output, fluid is pushed through the line connecting the syringe to the transducer (4), out the outlet valve (2) of Valve A or B and through the union.

With reciprocating syringes, when Syringe 1 is delivering to the system output, Syringe 2 is refilling and pre-pressurizing. When Syringe 2 is delivering to the system output, Syringe 1 is

refilling and pre-pressurizing.

Figure 4.19 shows a μ Pro fitted with high pressure active valves.

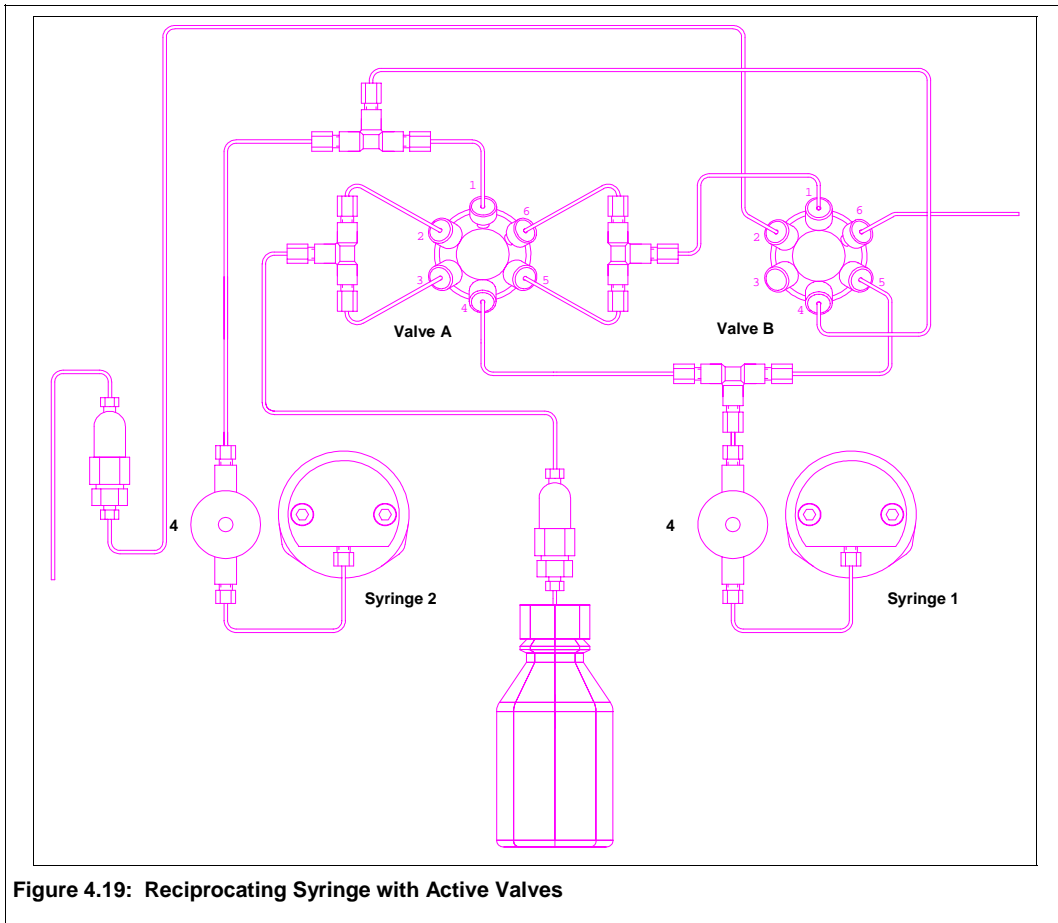

Figure 4.19: Reciprocating Syringe with Active Valves

When both syringe pistons retract for the initial refill, ports 1 and 2 on Valve A and ports 4 and 5 on Valve B are connected. The suction created by retracting the pistons pulls fluid from the reservoir, through ports 1 and 2 of Valve A. At the union after Valve A the flow splits between syringe 1 and 2. Flow travels to Syringe 1 through ports 4 and 5 of Valve B and the pressure transducer (4). Flow travels to Syringe 2 through the pressure transducer (4).

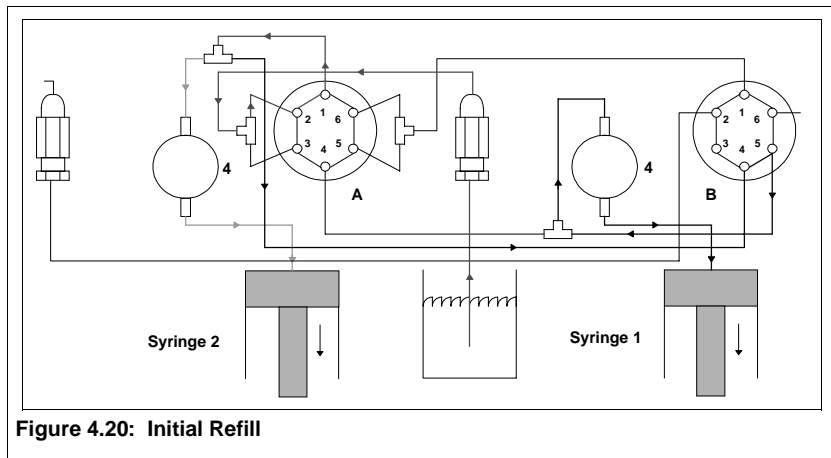
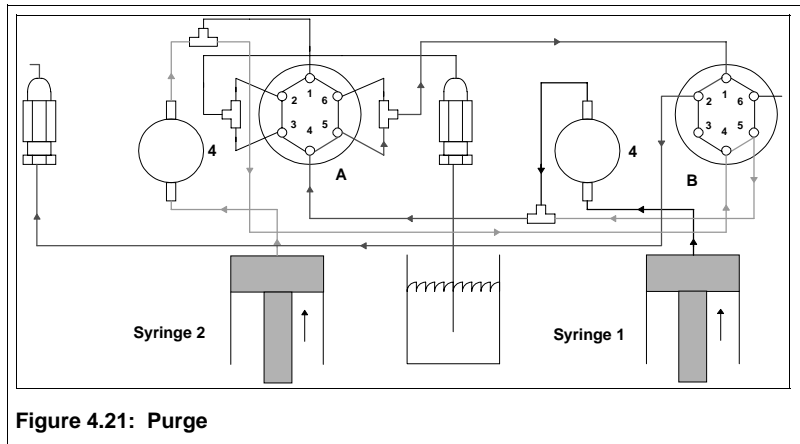

Figure 4.20: Initial Refill

When the syringes are purging, Valve A is turned to connect ports 4 and 5 and Valve B is turned to connect ports 1 and 2 and ports 4 and 5. Flow from syringe 1 goes through the transducer (4) to Valve A. From Valve A the flow moves through the union to Valve B and then out the purge

check valve. Flow from Syringe 2 goes through the transducer (4) to Valve B and then joins up with the flow from Syringe 1.



When the Syringe 1 is delivering to the system output, ports 4 and 5 on Valve A are connected. When the syringe moves forward, fluid is pushed through the line connecting the syringe to the pressure transducer (4) and the line connecting the transducer to valve A. The fluid moves out the union connected at port 5 of Valve A to port 1 of Valve B and out the line connected at port 6 of Valve B.

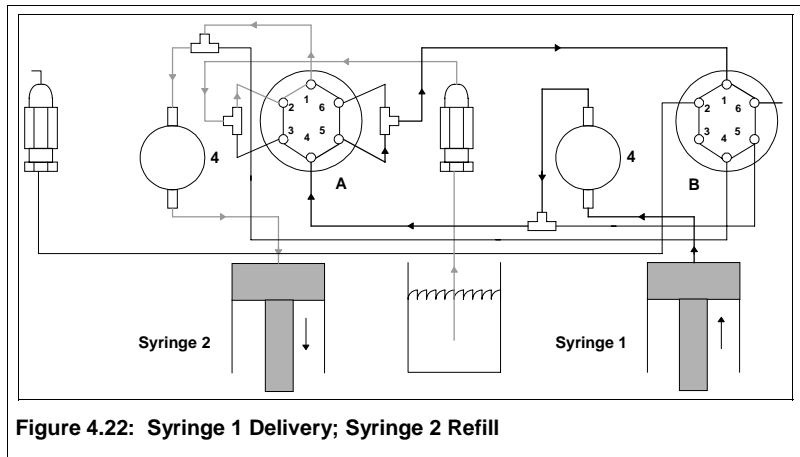

When the Syringe 2 is delivering to the system output, ports 1 and 6 on valve A are connected. When the syringe moves forward, fluid is pushed through the line connecting the syringe to the pressure transducer (4), through ports 1 and 6 of valve A and the lines connecting to port 1 on

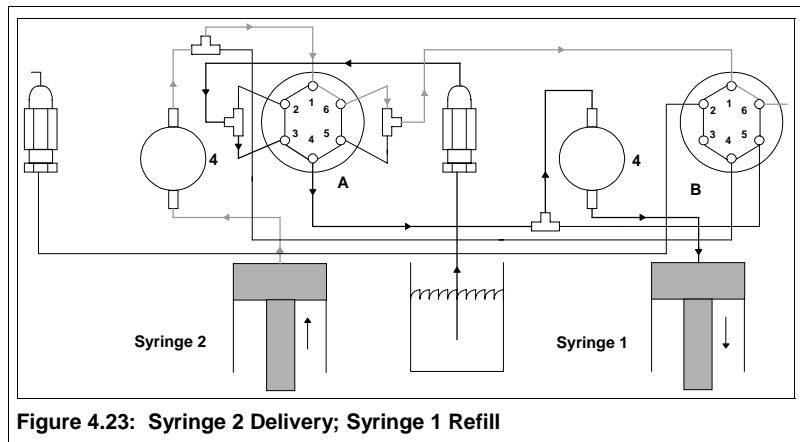

valve B. The fluid is transferred to port 6 of valve B and out the line connected at that point.

Exercise

In this exercise, we will create a three step file to run a reciprocating syringe system. The exercise will show how to program a new file to run the pump at a constant flow rate and how to ramp the flow.

Figure 4.21 represents the file we will create. Table 4.3 represents a listing of the file steps. The file we will program does not represent any particular application; but, is intended to convey an understanding of the different kinds of programming features available. You may wish to consult the exercise for single syringe operation to see some of the other programming features.

First, in the exercise you will create a new file and enter a high pressure limit of 2000 psi and a low pressure limit of 600 psi. You will also verify that the control mode of operation is flow.

Next, you will program your equilibration parameters. In this exercise those parameters are a five minute equilibration period at a flow rate of 10 $\mu\text{L}/\text{min}$.

The first program step of our exercise will continue under the conditions during equilibration.

After running at 10 $\mu\text{L}/\text{min}$. for 15 minutes, we will begin to ramp the flow over a five minute period down to zero.

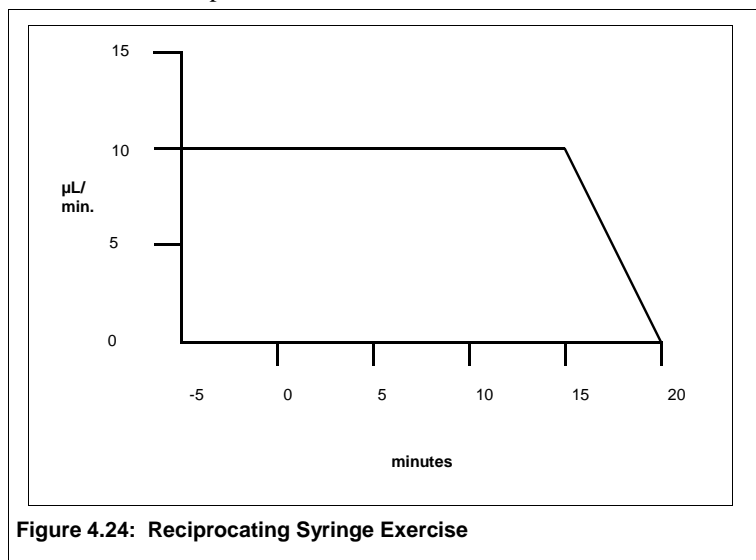
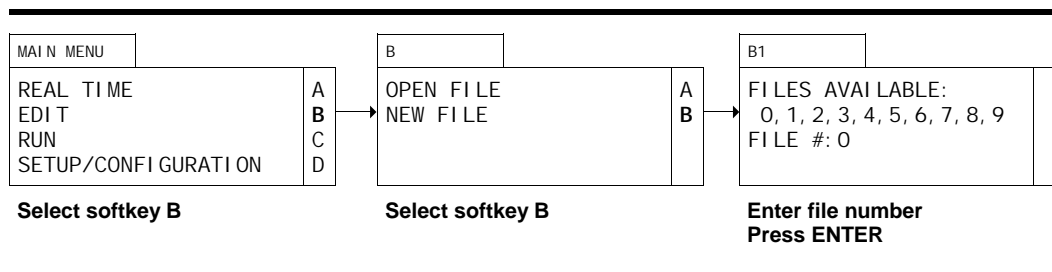

Table 4.3

Program Step	Time	Flow
Equilibration	5.00	10 μL
Step 1	0.00	10 μL
Step 2	15.00	10 μL
Step 3	20.00	0 μL

First: Create a New File

To create a new file, select softkey B (EDIT) from the Main Menu. The display will change to screen B. Select softkey B (NEW FILE) from screen B. The display will change to screen B1 and the cursor will blink on the FILE # field. Enter a valid file number and press ENTER.



Second: Enter General File Parameters

Once a valid file number has been entered, the display will change to display screen B2.1 and the cursor will blink on the HI LI MI T field. Enter **2000** and press ENTER. The cursor will move to the LO LI MI T field. Enter **600** and press ENTER. The cursor will move to the CONTROL field. Press softkey D to toggle to constant flow mode and press ENTER.

Before Programming

B2.1			
		REC	
HI LI MI T: XXXXX			
LO LI MI T: XXXXX			
CONTROL: FLOW	→		D

Enter **2000**; press ENTER
Enter **600**; press ENTER
Toggle softkey D to constant flow as shown

After Programming

B2.1			
		REC	
HI LI MI T: 2000			
LO LI MI T: 600			
CONTROL: FLOW	→		D

Press ENTER

Third: Program Equilibration

Once the general file parameters have been entered, the display will change to display screen B2.2 and the cursor will blink on the EQUI L TI ME field. Enter **5** and press ENTER since our exercise calls for a 5 minute equilibration.

The cursor will move to the FLOW field and blink. Enter **10** and press ENTER since our exercise calls for a flow rate of 10 μ L/min.

The cursor will move to the ON field and blink to the right of the first 0. Since we do not need to activate any events, press softkey D to scroll to the program screens.

Before Programming

B2.2			
EQUI L TI ME: 0.00			
FLOW: 0.00			
ON: 0 0 0 0 0 0	↑		C
	↓		D

Enter **5** for Equil Time; press ENTER
Enter **10** for Flow; press ENTER

After Programming

B2.2			
EQUI L TI ME: 5.00			
FLOW: 10.00			
ON: 0 0 0 0 0 0	↑		C
	↓		D

Press softkey D

Fourth: Step One

Once softkey D has been pressed in screen B2.2, the display will change to display screen B2.3 and the cursor will blink on the TIME field. Press ENTER to accept the default value of 0.00 (all files need a zero start time).

The cursor will move to the FLOW field. Press ENTER to accept the value carried forward from the Equilibration screen.

The cursor will move to the first ON field and blink to the right of the first 0. Since we do not need to activate any events, press softkey A to INSERT another program screen.

Before Programming

B2.3			
TIME:	0.00	INS	A
FLOW:	10	DEL	B
		↑	C
ON:	0 0 0 0 0 0		

Press ENTER to accept Time 0
Press ENTER to accept 10 $\mu\text{L}/\text{min}$.

After Programming

B2.3			
TIME:	0.00	INS	A
FLOW:	10	DEL	B
		↑	C
ON:	0 0 0 0 0 0		

Press softkey A to INSERT a new screen

Fifth: Step Two

Since the μPro generates a linear change between any two end points, we need to establish the first end point at ten minutes to start the ramp from 10 $\mu\text{L}/\text{min}$. to 0 $\mu\text{L}/\text{min}$. This program screen will establish that starting point.

Once softkey A has been pressed, the display will call up a new screen B2.3. It will appear identical to the screen just programmed and the cursor will blink in the TIME field. Enter **15** and press ENTER.

The cursor will move to the FLOW field. Enter **10** and press ENTER.

The cursor will move to the first event field. Since we do not need to activate any events, press softkey A to INSERT a new screen.

Before Programming

B2.3			
TIME:	-1.00	INS	A
FLOW:	10	DEL	B
		↑	C
ON:	0 0 0 0 0 0		

Press ENTER to accept Time 0
Press ENTER to accept 10 $\mu\text{L}/\text{min}$.

After Programming

B2.3			
TIME:	15.00	INS	A
FLOW:	10	DEL	B
		↑	C
ON:	0 0 0 0 0 0		

Press softkey A to INSERT a new screen

Sixth: Step Three

Once softkey A has been pressed, the display will call up a new screen B2.3. It will appear identical to the screen just programmed and the cursor will blink in the TIME field. Enter **20** and press ENTER.

The cursor will move to the FLOW field. Enter **0** and press ENTER.

The cursor will move to the first event field. Since we are done programming, you may press softkey C to scroll up through the individual program screens.

Before Programming

B2.3				
TIME:	-1.00	INS	A	
FLOW:	10	DEL	B	
		↑	C	
ON:	0 0 0 0 0 0			

Press ENTER to accept Time 0
Press ENTER to accept 10 µL/min.

After Programming

B2.3				
TIME:	20.00	INS	A	
FLOW:	0	DEL	B	
		↑	C	
ON:	0 0 0 0 0 0			

Press softkey C to scroll up

Summary

You can press softkeys C and D to scroll through the program steps to review them and verify that they have been entered correctly. You may find it useful to make a table similar to that shown on Table 4.2 before programming.

Press DISPLAY and ΔMENU to return to the Main Menu.

Gradient Mode

Plumbing

A μ Pro pump for gradient operation is fitted with low pressure active valves for intake and purge, and a high pressure active valve for output.

Figure 4.25 shows a μ Pro configured for binary operation. μ Pros configured for ternary operation have an additional single syringe slave installed to the left of the binary unit with a line of tubing going from the output of the single syringe to one of the additional mixer ports. Quaternary μ Pros have two additional single syringe slaves installed to the left of the binary unit.

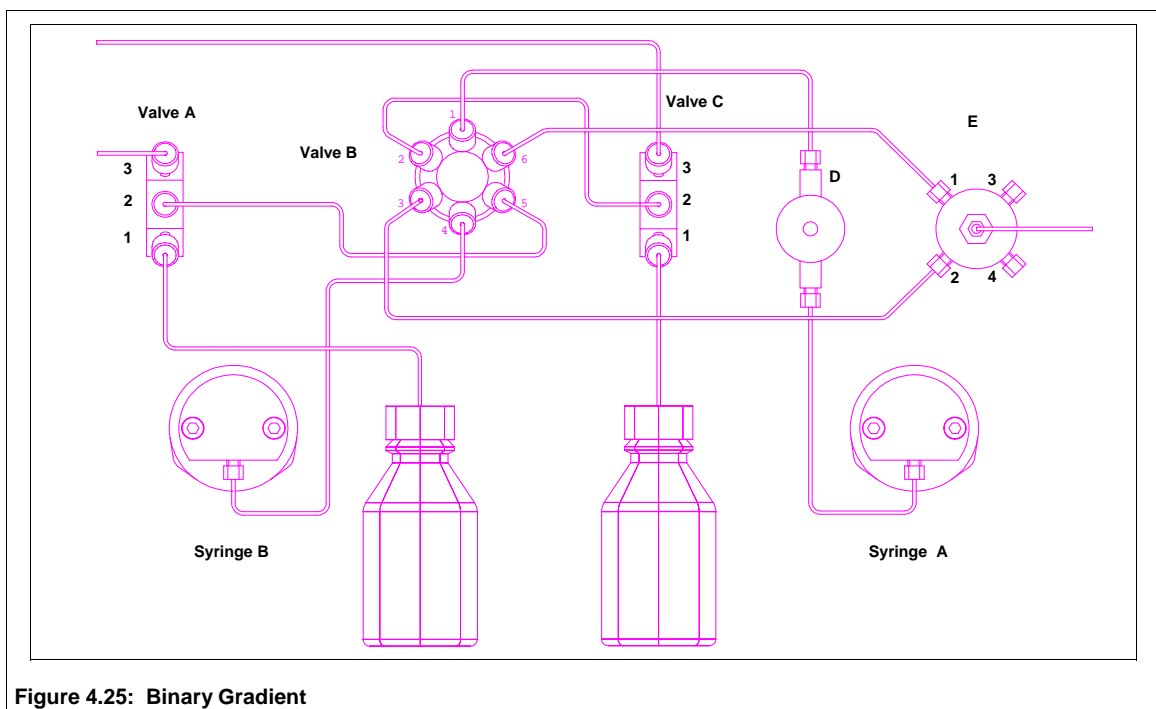

Figure 4.25: Binary Gradient

When the syringe A piston retracts to refill, valves B and C are turned to connect ports 1 and 2. The suction created by retracting the piston pulls fluid from the reservoir, through ports 1 and 2 on valve C. The fluid is pulled through the line connecting port 2 on valve C and port 2 on valve B, and consequently through the line connecting the pressure transducer (D) with port 1 on valve B and the line connecting the syringe with the pressure transducer.

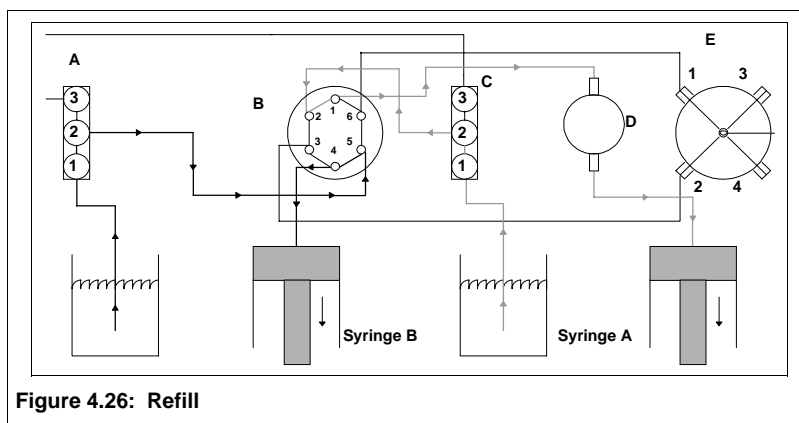

Figure 4.26: Refill

When the syringe B piston retracts to refill, valve A is turned to connect ports 1 and 2, and valve B is turned to connect ports 4 and 5. The suction created by retracting the piston pulls fluid from the reservoir, through ports 1 and 2 on valve A. The fluid is pulled through the connecting line between port 2 on valve A and port 5 on valve B, and consequently through the line connecting port 4 on valve B and the syringe.

When syringe A is being purged, valve B is turned to connect ports 1 and 2 and valve C is turned to connect ports 2 and 3. Thus, as the syringe piston moves forward, fluid is pushed through the line connecting the syringe to the pressure transducer (D), to port 1 on valve B, out port 2 on valve B, to port 2 on valve C and out the line at port 3 on valve C.

When syringe B is being purged, valve B is turned to connect ports 4 and 5 and valve A is turned to connect ports 2 and 3. Thus, as the syringe piston moves forward, fluid is pushed through the line connecting the syringe to port 4 on valve B, out the line connected at port 5 on valve B, to port 2 on valve A and out the line at port 3 on valve A.

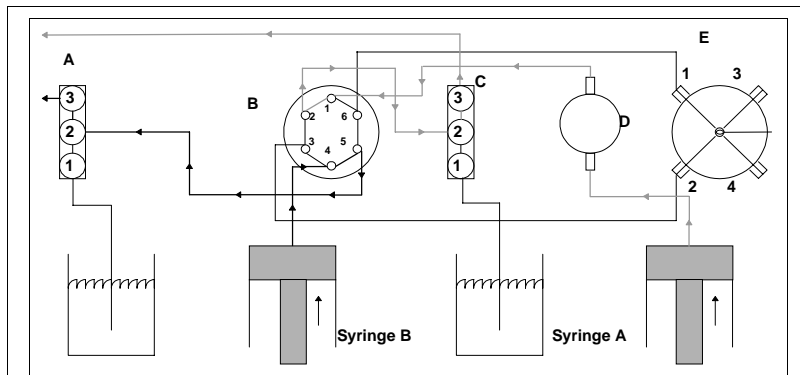

Figure 4.27: Purge

When syringes A and B are delivering to the system output, ports 1 and 6, and 4 and 3 on valve B are connected. Syringe A delivers fluid to port 1 on the mixer (E) and syringe B delivers fluid to port 2 on the mixer (E).

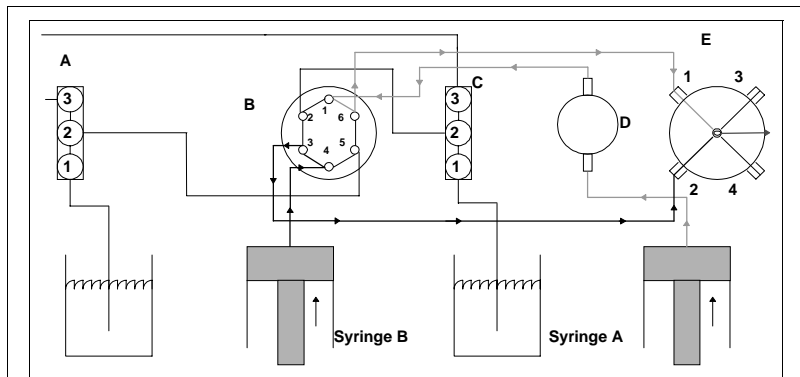

Figure 4.28: Delivery

Exercise

In this exercise, we will create a nine step file to run a gradient. In this exercise we will illustrate several programming features of the μ Pro. The exercise will show how to program a new file to run a binary, multi-linear gradient, activate external events, and step the flow.

First, in the exercise you will enter a high pressure limit of 1500 psi and a low pressure limit of 500 psi. You will also verify that the control mode of operation is flow.

Next, you will program your equilibration parameters. In this exercise those parameters are a 20 minute equilibration period at a flow rate of 10 μ L/min. and %B of 5%. You will also activate event 1 at the beginning of equilibration.

At the end of equilibration, we will turn off event 1. The first program step will also activate event 2 and run the syringes at a flow rate of 10 μ L/min., continuing at 5%B.

The next step will turn off event 2.

The next few steps will ramp the gradient composition to 30% over a five minute period, followed by a ramp to 50% over a ten minute period, a ramp to 70% over a 25 minute period and a ramp to 80% over a 20 minute period, where we will hold the gradient at 80% for 20 minutes.

The last steps will step the flow to .05 μ L/min to allow the system to decompress prior to refilling the syringes.

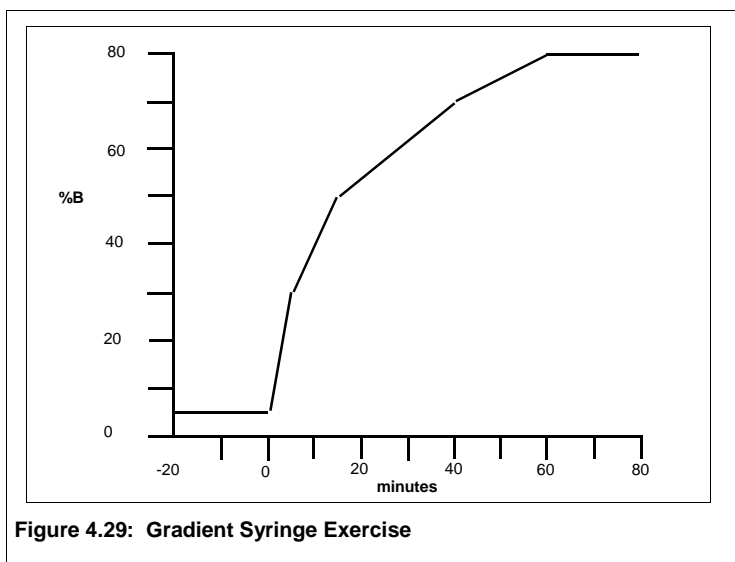

Figure 4.29: Gradient Syringe Exercise

Table 4.4: Gradient Syringe Exercise

Program Step	Time	Flow	%B	Events
Equilibration	20.00	10.00 μ L	5	1 ON
Step 1	0.00	10.00 μ L	5	1 OFF, 2 ON
Step 2	0.05	CLEAR	-	2 OFF
Step 3	5.00	10.00 μ L	30	-
Step 4	15.00	10.00 μ L	50	-
Step 5	40.00	10.00 μ L	70	-
Step 6	60.00	10.00 μ L	80	-
Step 7	70.00	10.00 μ L	80	-
Step 8	70.01	0.05 μ L	80	-
Step 9	80.01	0.05 μ L	80	-

Figure 4.26 represents the file we will create. Table 4.4 represents a listing of the file steps. The file we will program does not represent any particular application; but, is intended to convey an understanding of the different kinds of programming features available. You may wish to consult the exercise for single syringe operation to see some of the other programming features.

First: Create a New File

To create a new file, select softkey B (EDI T) from the Main Menu. The display will change to screen B. Select softkey B (NEW FI LE) from screen B. The display will change to screen B1 and the cursor will blink on the FI LE # field. Enter a valid file number and press ENTER.

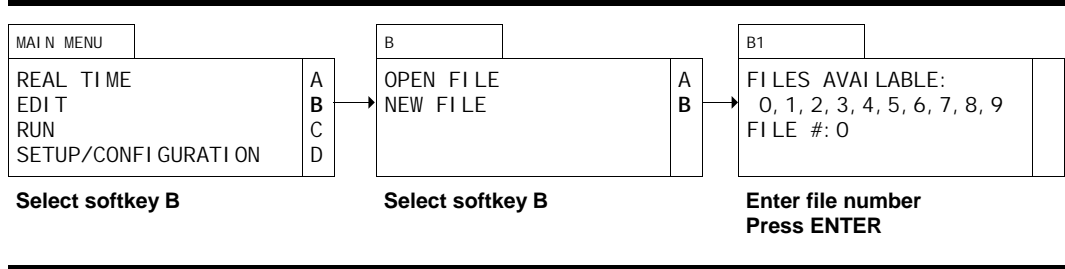

Second: Enter General File Parameters

Once a valid file number has been entered, the display will change to display screen B2.1 and the cursor will blink on the HI LIMIT field. Enter **1500** and press ENTER. The cursor will move to the LO LIMIT field. Enter **500** and press ENTER. The cursor will move to the CONTROL field. Press softkey D to toggle to constant flow mode and press ENTER.

Before Programming

B2.1	
HI LIMIT: XXXXX	
LO LIMIT: XXXXX	

**Enter 1500; press ENTER
Enter 500; press ENTER**

After Programming

B2.1	
HI LIMIT: 1500	
LO LIMIT: 500	

Press ENTER

Third: Program Equilibration

Once the general file parameters have been entered, the display will change to display screen B2.2 and the cursor will blink on the EQUIL TIME field. Enter **20** and press ENTER since our exercise calls for a 20 minute equilibration.

The cursor will move to the FLOW field and blink. Enter **10** and press ENTER since our exercise calls for a flow rate of 10 µL/min.

The cursor will move to the %B field. Enter **5** since we want to equilibrate under conditions of 5% B. Press ENTER.

The cursor will move to the ON field and blink to the right of the first 0. The first 0 corresponds

Before Programming

B2.2	
EQUIL TIME: 0.00	
FLOW: 0.00	
%B: 0	↑ C
ON: 0 0 0 0 0	↓ D

**Enter 5 for Equil Time; press ENTER
Enter 10 for Flow; press ENTER
Enter 5 for %B; press ENTER
Enter "1" in first ON field; press ENTER**

After Programming

B2.2	
EQUIL TIME: 5.00	
FLOW: 10.00	
%B: 5	↑ C
ON: 1 0 0 0 0	↓ D

Press softkey D

to the contact closure labeled 1 and 2 on the I/O board. Since we want to turn this contact on at the beginning of equilibration, press **1** and ENTER.

The cursor will move to the second ON field; however since we only need to activate the first contact, press softkey D to scroll to the program screens.

Fourth: Step One

Once softkey D has been pressed in screen B2.2, the display will change to display screen B2.3 and the cursor will blink on the TIME field. Press ENTER to accept the default value of 0.00 (all files need a zero start time).

The cursor will move to the FLOW field. Press ENTER to accept the value carried forward from the Equilibration screen.

The cursor will move to the %B field. Press ENTER to accept the value carried forward from the Equilibration Screen.

The cursor will move to the first ON field and blink to the right of the first event field. Press **0** to turn off the first event. Press ENTER. The cursor will move to the second ON field. Press **1** to turn on the second event. Press ENTER. The cursor will move to the third ON field; however, since we only need to activate the second contact, press softkey A to INSERT another program screen.

Before Programming

B2.3			
TIME:	0.00	INS	A
FLOW:	10	DEL	B
%B:	5	↑	C
ON:	1 0 0 0 0 0		

Press ENTER to accept Time 0
 Press ENTER to accept 10 µL/min.
 Press ENTER to accept 5%B
 Press 0, ENTER, 1, ENTER to turn off event 1 and on event 2

After Programming

B2.3			
TIME:	0.00	INS	A
FLOW:	10	DEL	B
%B:	5	↑	C
ON:	0 1 0 0 0 0		

Press softkey A to INSERT a new screen

Fifth: Step Two

Once softkey A has been pressed, the display will call up a new screen B2.3. It will appear identical to the screen just programmed and the cursor will blink in the TIME field.

The only function we need to execute is to turn off the second contact closure event. To do this, enter enter **.05** in the TIME field (to turn off the second event .05 minutes after the start of the program). Press ENTER.

The cursor will move to the FLOW field. Press CLEAR to enter an event activity without affecting flow or gradient composition (NA will now be displayed in the FLOW field).

The cursor will move to the %B field. Press ENTER to accept the value of 5%.

The cursor will move to the first ON field. Press ENTER to accept the off (0) value. The cursor will move to the second ON field. Press **0** to turn off the second event. Press ENTER. The cursor will move to the third ON field; however, since we only need to deactivate the second contact, press softkey A to INSERT another program screen.

Before Programming

B2.3			
TIME:	-1.00	INS	A
FLOW:	10	DEL	B
%B:	5	↑	C
ON:	0 1 0 0 0 0		

Enter .05 for Time
Press CLEAR to only affect events
Press ENTER to accept %B
Press ENTER, 0, ENTER to turn off 2

After Programming

B2.3			
TIME:	0.05	INS	A
FLOW:	NA	DEL	B
%B:	5	↑	C
ON:	0 0 0 0 0 0		

Press softkey A to INSert a new screen

Sixth: Step Three

Once softkey A has been pressed, the display will call up a new screen B2.3. The cursor will blink in the TIME field. Enter 5 and press ENTER.

The cursor will move to the FLOW field. Enter **10** and press ENTER.

The cursor will move to the %B field. Enter **30** since we want to ramp from 5%B to 30%B during the first 5 minutes of the program. Press ENTER.

The cursor will move to the first event field. Since we do not need to activate any events, press softkey A to INSert a new screen.

Before Programming

B2.3			
TIME:	-1.00	INS	A
FLOW:	NA	DEL	B
%B:	5	↑	C
ON:	0 0 0 0 0 0		

Enter 5 for Time; press ENTER
Enter 10 for Flow; press ENTER
Enter 30 for %B

After Programming

B2.3			
TIME:	5.00	INS	A
FLOW:	10	DEL	B
%B:	30	↑	C
ON:	0 0 0 0 0 0		

Press softkey A to INSert a new screen

Seventh: Step Four

Once softkey A has been pressed, the display will call up a new screen B2.3. The cursor will blink in the TIME field. Enter **15** and press ENTER.

The cursor will move to the FLOW field. Press ENTER to accept the displayed value.

The cursor will move to the %B field. Enter **50** since we want to ramp from 30%B to 50%B during the next 10 minutes of the program. Press ENTER.

Before Programming

B2.3				
TIME:	-1.00	INS	A	
FLOW:	10	DEL	B	
%B:	30	↑	C	
ON:	0 0 0 0 0 0			

Enter 15 for Time; press ENTER
Press ENTER to accept Flow.
Enter 50 for %B

After Programming

B2.3				
TIME:	15.00	INS	A	
FLOW:	10	DEL	B	
%B:	50	↑	C	
ON:	0 0 0 0 0 0			

Press softkey A to INsert a new screen

The cursor will move to the first event field. Since we do not need to activate any events, press softkey A to INsert a new screen.

Eighth: Fifth Program Screen

Once softkey A has been pressed, the display will call up a new screen B2.3. The cursor will blink in the TIME field. Enter **40** and press ENTER.

The cursor will move to the FLOW field. Press ENTER to accept the displayed value.

The cursor will move to the %B field. Enter **70** since we want to ramp from 50%B to 70%B during the next 25 minutes of the program. Press ENTER.

The cursor will move to the first event field. Since we do not need to activate any events, press softkey A to INsert a new screen.

Before Programming

B2.3				
TIME:	-1.00	INS	A	
FLOW:	10	DEL	B	
%B:	50	↑	C	
ON:	0 0 0 0 0 0			

Enter 40 for Time; press ENTER
Press ENTER to accept Flow
Enter 70 for %B

After Programming

B2.3				
TIME:	40.00	INS	A	
FLOW:	10	DEL	B	
%B:	70	↑	C	
ON:	0 0 0 0 0 0			

Press softkey A to INsert a new screen

Ninth: Step Six

Once softkey A has been pressed, the display will call up a new screen B2.3. The cursor will blink in the TIME field. Enter **60** and press ENTER.

The cursor will move to the FLOW field. Press ENTER to accept the displayed value.

The cursor will move to the %B field. Enter **80** since we want to ramp from 70%B to 80%B during the next 20 minutes of the program. Press ENTER.

Before Programming

B2.3				
TIME:	-1.00	INS	A	
FLOW:	10	DEL	B	
%B:	70	↑	C	
ON:	0 0 0 0 0 0			

Enter 60 for Time; press ENTER
Press ENTER to accept Flow
Enter 80 for %B

After Programming

B2.3				
TIME:	60.00	INS	A	
FLOW:	10	DEL	B	
%B:	80	↑	C	
ON:	0 0 0 0 0 0			

Press softkey A to INsert a new screen

The cursor will move to the first event field. Since we do not need to activate any events, press softkey A to INsert a new screen.

Tenth: Step Seven

Once softkey A has been pressed, the display will call up a new screen B2.3. The cursor will blink in the TIME field. Enter **70** and press ENTER.

The cursor will move to the FLOW field. Press ENTER to accept the displayed value.

The cursor will move to the %B field. Press ENTER.

The cursor will move to the first event field. Since we do not need to activate any events, press

Before Programming

B2.3				
TIME:	-1.00	INS	A	
FLOW:	10	DEL	B	
%B:	80	↑	C	
ON:	0 0 0 0 0 0			

Enter 70 for Time; press ENTER
Press ENTER to accept Flow
Press ENTER to accept 80 for %B

After Programming

B2.3				
TIME:	70.00	INS	A	
FLOW:	10	DEL	B	
%B:	80	↑	C	
ON:	0 0 0 0 0 0			

Press softkey A to INsert a new screen

softkey A to INsert a new screen.

Eleventh: Step Eight

Once softkey A has been pressed, the display will call up a new screen B2.3. The cursor will blink in the TIME field. Enter **70.01** and press ENTER.

The cursor will move to the FLOW field. Enter **.05** and press ENTER. The flow will ramp from 10 $\mu\text{L}/\text{min}$ to .05 $\mu\text{L}/\text{min}$ during the time from 70 to 70.01 minutes.

The cursor will move to the %B field. Press ENTER.

The cursor will move to the first event field. Since we do not need to activate any events, press

Before Programming

B2.3				
TIME:	-1.00	INS	A	
FLOW:	10	DEL	B	
%B:	80	↑	C	
ON:	0 0 0 0 0 0			

Enter 70.01 for Time; press ENTER
Enter .05 for Flow; press ENTER
Press ENTER to accept 80 for %B

After Programming

B2.3				
TIME:	70.01	INS	A	
FLOW:	0.05	DEL	B	
%B:	80	↑	C	
ON:	0 0 0 0 0 0			

Press softkey A to INsert a new screen

softkey A to INsert another program screen.

Twelfth: Step Nine

Once softkey A has been pressed, the display will call up a new screen B2.3. The cursor will blink in the TIME field. Enter **80** and press ENTER.

The cursor will move to the FLOW field. Press ENTER to accept displayed value.

The cursor will move to the %B field. Press ENTER.

The cursor will move to the first event field. Since are done programming, press softkey C to scroll up through the individual program screens.

Before Programming

B2.3				
TIME:	-1.00	INS	A	
FLOW:	0.05	DEL	B	
%B:	80	↑	C	
ON:	0 0 0 0 0 0			

Enter 80 for Time; press ENTER
Press ENTER to accept Flow
Press ENTER to accept 80 for %B

After Programming

B2.3				
TIME:	80	INS	A	
FLOW:	0.05	DEL	B	
%B:	80	↑	C	
ON:	0 0 0 0 0 0			

Press softkey C to scroll up

Summary

You can press softkeys C and D to scroll through the program steps to review them and verify that they have been entered correctly. You may find it useful to make a table similar to that shown on Table 4.2 before programming.

Press DISPLAY and ΔMENU to return to the Main Menu.

Continuous Flow Gradient Mode

Plumbing

A μ Pro pump for continuous flow gradient operation is a specific configuration designed to maintain system pressure at all times, even during gradient pump refill. The following figures illustrate the flow schematics for this option.

Figure 4.30 shows a transitional liquid delivery (TLD) module. A gradient system mixer output is plumbed from the left of the TLD to port 5 of valve C on the TLD.

Theory of Operation

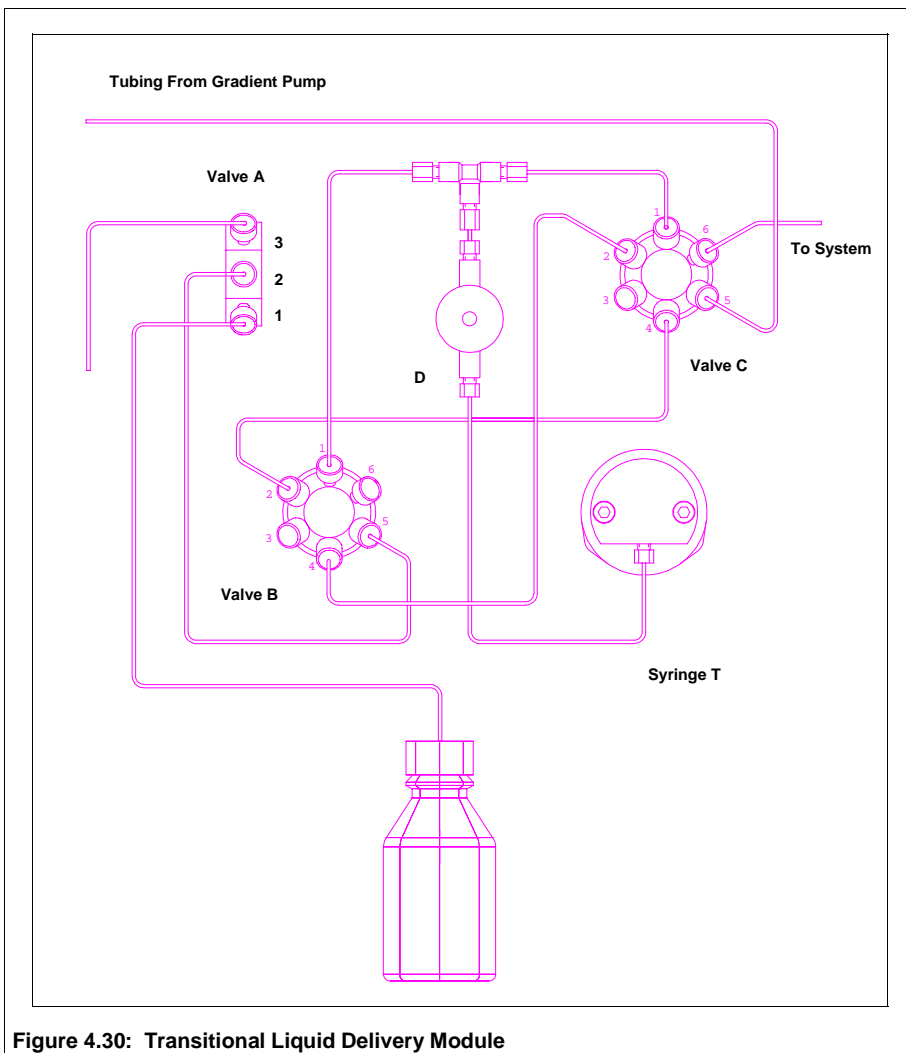

Figure 4.30: Transitional Liquid Delivery Module

Syringe pumps are effective at delivering very low flow rates without pulsation. Previously, a potential drawback with using syringe pumps in liquid chromatography has been the need to refill the syringes between runs. Refilling results in an interruption in flow and a loss of system pressure. The addition of a transitional liquid delivery (TLD) module to a gradient system eliminates this issue by creating a continuous flow syringe system.

The TLD module is connected to the output of the gradient pump on port 5 of valve C. When the gradient pump is delivering to the downstream devices, ports 5 and 6 are connected. The TLD module refills and pre-pressurizes to a dead head, reading the pressure of the gradient pump. Once the gradient pump has finished the run, the TLD module is brought on-line by connecting ports 1 and 6 of valve C. The

TLD module runs for the user programmed amount of time. During the time the TLD module is connected to the downstream devices, the gradient pump refills and pre-pressurizes to a dead head, reading the pressure of the TLD module. The gradient pump is then switched back on-line to the downstream devices and the entire procedure is repeated.

The TLD module has four basic states: purge, refill, pre-pressurize, and output.

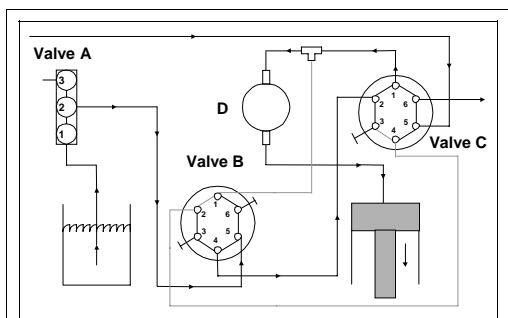

Figure 4.31: TLD Refill (Gradient Delivery)

Figure 4.31 shows the flow schematic of the TLD refilling. Valves A and C are turned to connect ports 1 and 2, valve B is turned to connect ports 4 and 5. The suction created by retracting the piston pulls fluid from the reservoir, through ports 1 and 2 of valve A, through the line connecting port 2 on valve A and port 5 on valve B, and consequently through the line connecting port 4 on valve B and port 2 on valve C. Finally, the fluid is pulled through the lines connecting port 1 on valve C with the pressure transducer (D) and the syringe.

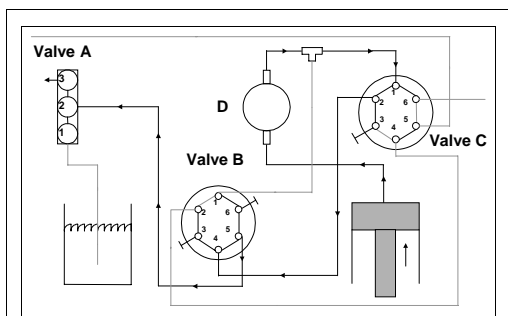

Figure 4.32: TLD Purge

Figure 4.32 shows the flow schematic of the TLD purging. Valve A is turned to connect ports 3 and 2. Valve B is turned to connect ports 4 and 5. valve C is turned to connect ports 1 and 2. As the syringe piston moves forward, fluid is pushed through the line connecting the syringe to the pressure transducer (D), to port 1 on valve C, out port 2 on valve C, to port 4 on valve B and out the line connecting port 5 of valve B and port 2 of valve A. Finally, the fluid is pushed through the line connected at port 3 of valve A.

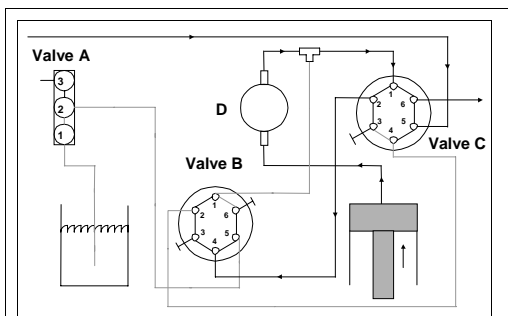

Figure 4.33: TLD Pre-Pressurize (Gradient Delivery)

Figure 4.33 shows the flow schematic of the TLD pre-pressurizing. Valve B is connected on ports 3 and 4 and valve C is connected on ports 1 and 2. As the syringe piston moves forward, fluid is pushed through the lines connecting the syringe to the pressure transducer (D) and port 1 of valve C. The fluid moves through the line connecting port 2 of valve C and port 4 of valve B. Since port 3 of valve B is plugged, the system is delivering to a dead head.

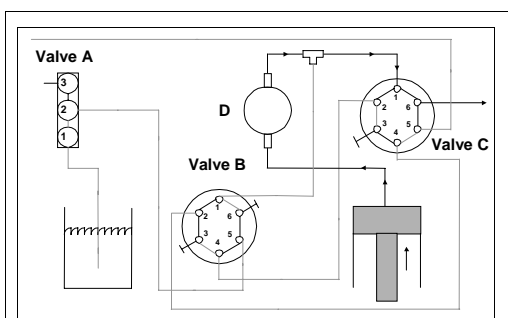

Figure 4.34: TLD Delivery (Gradient Refill/Pre-Pressurize)

Figure 4.34 shows the flow schematic of the TLD delivering to the downstream devices. Valve C is connected on ports 1 and 6. As the syringe piston moves forward, fluid is pushed through the line connecting the syringe to the pressure transducer (D) and port 1 of valve C. The fluid moves out port 6.

Linking Files

File/Cycle

In the File/Cycle method of linking files, the μ Pro allows you to enter up to 6 files and cycle each file up to 999 times. If you enter 0 in the CYCLES field, the file will cycle infinitely.

In this exercise, we will create a file link which will run four files (0, 1, 2, 3,). We will run file 0 a total of 25 times, followed by file 1 to be run 3 times, followed by file 2 to be run 14 times, ending with file 3 being run once (for example, we may have programmed file 3 to work as a “terminal” file, turning the pump flow to zero and turning events off).

Step One: Creating a File Link

To create a file link, select softkey C (RUN) from the Main Menu. The display will change to screen C. Select softkey B (FILE/CYCLE) from screen C.

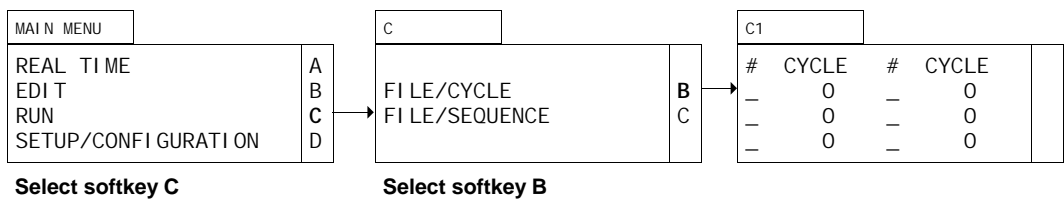

Step Two: Creating a File/Cycle

The display will change to screen C1 and the cursor will blink in the # field. Enter **0** and press ENTER. The cursor will move to the CYCLE field and blink. Enter **25** and press ENTER.

Before Programming

C1
CYCLE # CYCLE
- 0 - 0
- 0 - 0
- 0 - 0

Enter **0** for #; press ENTER
Enter **25** for CYCLES; press ENTER

After Programming

C1
CYCLE # CYCLE
0 25 - 0
- 0 - 0
- 0 - 0

The cursor will move to the next # field and blink. Enter **1** and press ENTER. The cursor will move to the next CYCLE field and blink. Enter **3** and press ENTER.

Before Programming

C1			
#	CYCLE	#	CYCLE
0	25	-	0
-	0	-	0
-	0	-	0

After Programming

C1			
#	CYCLE	#	CYCLE
0	25	1	3
-	0	-	0
-	0	-	0

Enter 1 for #; press ENTER
Enter 3 for CYCLES; press ENTER

The cursor will move to the next # field and blink. Enter **2** and press ENTER. The cursor will move to the next CYCLE field and blink. Enter **14** and press ENTER.

Before Programming

C1			
#	CYCLE	#	CYCLE
0	25	1	3
-	0	-	0
-	0	-	0

After Programming

C1			
#	CYCLE	#	CYCLE
0	25	1	3
2	14	-	0
-	0	-	0

Enter 2 for #; press ENTER
Enter 14 for CYCLES; press ENTER

The cursor will move to the next # field and blink. Enter **3** and press ENTER. The cursor will move to the next CYCLE field and blink. Enter **1** and press ENTER.

Before Programming

C1			
#	CYCLE	#	CYCLE
0	25	1	3
2	14	-	0
-	0	-	0

After Programming

C1			
#	CYCLE	#	CYCLE
0	25	1	3
2	14	3	1
-	0	-	0

Enter 3 for #; press ENTER
Enter 1 for CYCLES; press ENTER

Press RUN to run files

The cursor will move to the next # field. Since we are done linking files, you may press RUN to run the File/Cycles.

File/Sequence

In the File/Sequence method of linking file, the μ Pro allows you to enter up to 9 files and run them in sequence up to 999 times. If you enter 0 in the # OF CYCLES field, the file will cycle infinitely. You may also enter a terminal file to run once at the end of the sequence.

In this exercise, we will create a file link which will run three files (0, 1, 2) to be run in sequence five times. We will program file 3 to run once at the end of the sequence (for example, we may have programmed file 3 to work as a “terminal” file, turning the pump flow to zero and turning events off). When programmed, the μ Pro will run file 0 followed by file 1, followed by file 2, and repeat this sequence five times. Then the system will run file 3 once.

Step One: Selecting a File/Sequence

To create a file link, select softkey C (RUN) from the Main Menu. The display will change to screen C. Select softkey C (FILE/SEQUENCE) from screen C.

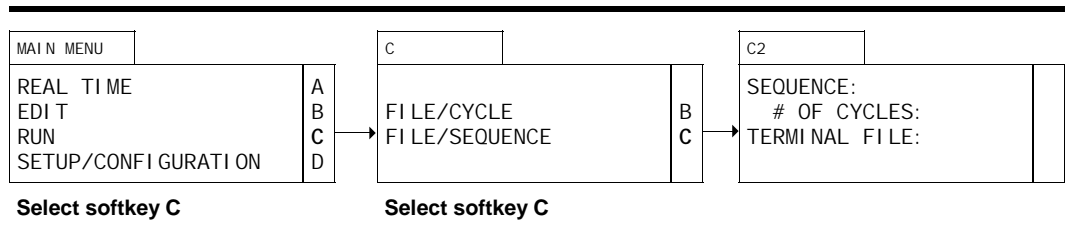

Step Two: Creating a File/Sequence

The display will change to screen C2 and the cursor will blink in the SEQUENCE field. Enter **0**, then **1**, then **2**, and press ENTER.

Before Programming

C2	
SEQUENCE:	
# OF CYCLES:	
TERMINAL FILE:	

Enter **0 1 2**; press ENTER

After Programming

C2	
SEQUENCE: 012	
# OF CYCLES:	
TERMINAL FILE:	

The cursor will move to the # OF CYCLES field and blink. Enter **5** and press ENTER.

Before Programming

C2	
SEQUENCE: 012	
# OF CYCLES:	
TERMI NAL FI LE:	

Enter 5; press ENTER

After Programming

C2	
SEQUENCE: 012	
# OF CYCLES: 5	
TERMI NAL FI LE:	

The cursor will move to the TERMINAL FILE field and blink. Enter **3** and press ENTER.

Before Programming

C2	
SEQUENCE: 012	
# OF CYCLES: 5	
TERMI NAL FI LE:	

Enter 3; press ENTER

After Programming

C2	
SEQUENCE: 012	
# OF CYCLES: 5	
TERMI NAL FI LE: 3	

Press RUN to run files

Since we are done linking files, you may press RUN to run the File/Cycles.